

HOLDING TANK LEVEL FLOAT ROD REPLACEMENT KIT

Please read complete instructions before replacing components.

Parts Included

Your kit will include the following:

Part #	Qty	Description
100364	1	ASSEMBLY,LEVEL FLOAT, H.T.
OR		
101091	1	ASSEMBLY,LEVEL FLOAT, H.T.
100066	1	BOILER TANK FLOAT GASKET SILIC

Tools Required

Red Robertson Screwdriver
7/16" Deep Well Socket w/ Ratchet
Vice Grips

Assembly Instructions

1. Drain the holding tank, storing the distilled water for future use if possible. Disconnect float box cable from distiller head. Lift head off of holding tank and place aside.
2. Remove the screws on the float box cover and remove cover.
3. Remove the nuts attaching the ground wire and lexan switch plate to the float rod studs. Lift switch plate off of studs.
4. Remove the nuts and washers holding the float rod to the float box and remove the float rod. Remove the float box as well as the old gasket underneath.
5. Unscrew the float from the old float rod and screw it onto the new rod. **DO NOT BEND THE FLOAT ROD.** This may require holding the float rod with vice grips.
6. Place the new rod inside the holding tank and through the studs in the same alignment that it was removed. While still supporting the float rod, place the new gasket over the studs. Place the float box over the studs and fasten with nuts and washers.
7. Attach the lexan switch plate, ensuring that the switches face up. Attach the ground screw. Place covers on float box and replace distiller head on holding tank. Connect float box cable to distiller head.

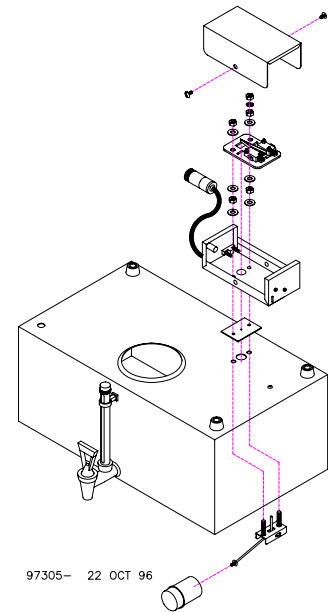

The distiller should now function properly. If it does not, we suggest taking your distiller to an authorized service representative.