

6. If you are replacing the pump shutoff float, use your fingers to compress the sides of the snap bushing on the float clip. Push the bushing up and through the clip welded to the inside of the tank. This may require twisting the clip, as shown in the blown-up portion of **Figure 2**. Remove the pump shutoff rod. Use the vice grips to grasp the rod and replace the float. Place rod in position in tank and snap bushing into clip.

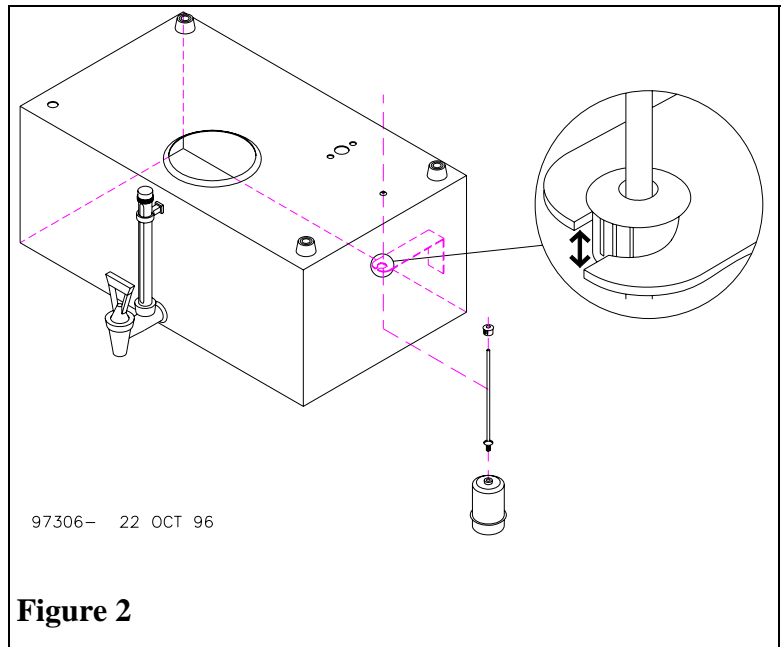

7. Place the level float rod inside the holding tank and through the studs in the same alignment that it was removed. While still supporting the float rod, place the new gasket over the studs. Place the float box over the studs and fasten according to **Figure 1**.
8. Attach the lexan switch plate and ground ring, ensuring that the front switch is facing the front of the distiller. Place covers on float box and replace distiller head on holding tank. Connect float box cable to distiller head.

The distiller should now function properly. If it does not, we suggest taking your distiller to an authorized service representative.