

FAN BLADE INSTALLATION KIT

Please read complete instructions before replacing components.

Parts Included

Your kit will include one of the following:

Part #	Qty	Description
100088	1	FAN BLADE,ALUMINUM,7"
		OR
101061	1	FAN BLADE,ALUMINUM,8"

Tools Required

Red Robertson Screwdriver
#2 Phillips Screwdriver
Adjustable (Crescent) Wrench
1/8" Hex (Allen) Wrench

Assembly Instructions

1. Ensure that the correct part is included in your replacement kit. A "26" model distiller will use a 7" blade while a "42" model distiller uses an 8" blade.
2. Drain the boiler tank. **CAUTION: DRAIN VALVE MAY BE VERY HOT.**
3. Turn main power switch on distiller off and unplug cord from wall plug.
4. Remove the distiller covers. This will require disconnecting the water feed line and brass reducer on 26-CT, 26D-8, 26C-8 and 26-14 models. **ENSURE THE SADDLE VALVE IS CLOSED BEFORE DISCONNECTING WATER FEED LINE.**
5. Using the hex wrench, remove the set screw attaching the fan blade to the motor shaft. This is best done from the rear of the distiller. Slide blade up & over motor shaft and out the back of the distiller. This may require GENTLY lifting the condensing coil. **DO NOT WARP COIL.**
6. Attach the new fan blade to the motor. Blade height must be adjusted so that there are no obstructions during rotations. Turn blade by hand to check for obstructions. Reattach covers. Ensure impurities drain valve is closed. Reattach water feed line if it was removed and open saddle valve.

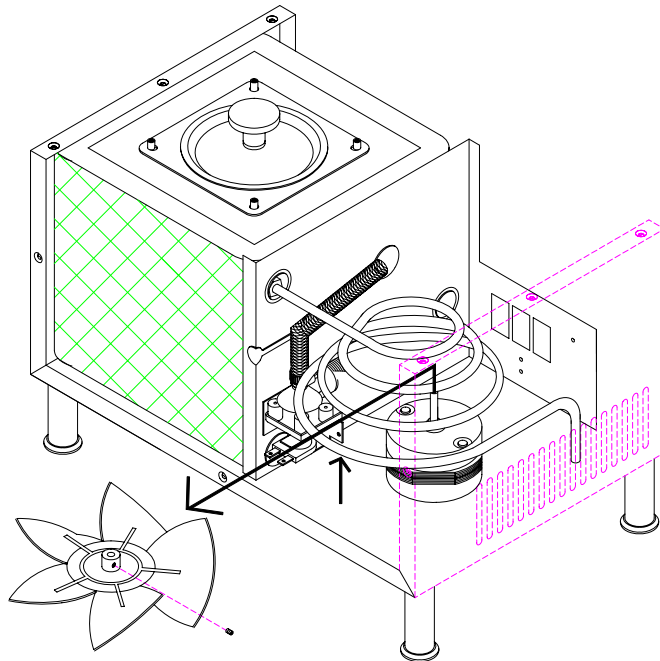

97314- 15.11.96

The distiller should now operate properly. If it does not, we suggest you take your distiller to an authorized service representative.